



**Automatic
Entrance
Systems**

Magnum Board II

Wiring & Adjustment Manual

for

GT-300/400/500 Operator

NABCO ENTRANCES Inc.

S82 W18717 Gemini Drive

P.O. Box 906

Muskego, WI 53150

Phone: 877-622-2694

Fax: 888-679-3319

Technical Assistance: 866-622-8325

www.nabcoentrances.com

Email: info@nabcoentrances.com

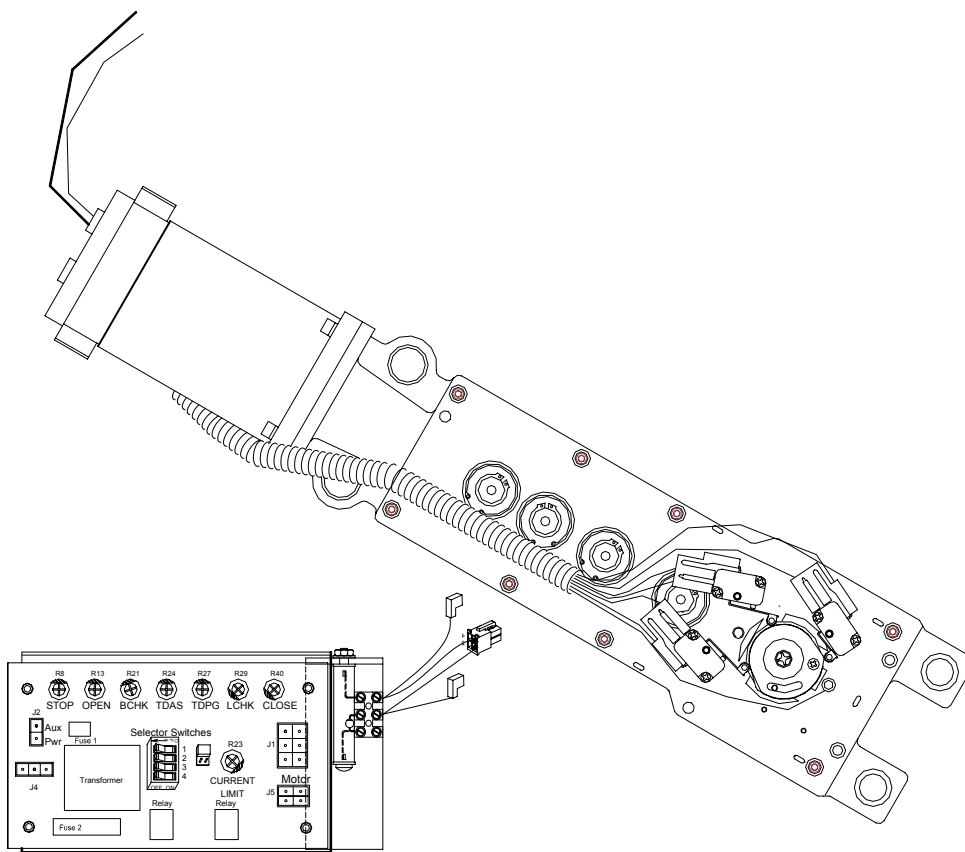

WARNING

Do not install, operate or service this product unless you have read and understand the Safety Practices, Warnings, Installation and Operating Instructions contained in this manual. Failure to do so may result in property damage, or bodily injury.

Part Number 1510319

July 27, 2004 Revision

for Swing operator

Table of Contents

Page 3	Overview of Magnum Controller
Page 4	Electrical Power - Wiring Connectors
Page 5	Pin Assignments
Page 6	Fuses
Page 7	Functions
Page 8	Adjustments
Page 9-11	Customized Settings Magnum Board Potentiometers
Page 12	Dip Switches, Control Switches and Signage
Page 13-16	Wiring to Operator

Overview of Magnum Controller

- All adjustments should be made with a small screwdriver. **DO NOT** use a pencil.
- The ground wire must be attached to the ground screw, which is located in the header.
- Reference ANSI standard 156.19 for low-energy swingers to make sure settings comply with codes.

By setting of Shunt, Magnum Board can control Standard swing operator or Low Energy operator.

1. The amount of energy stored in the door and imparted to an object on impact is determined by both the weight and speed of the door. NABCO Entrances Inc. recommends setting opening and closing speeds as slow as owners will accept, **AND** below the maximums stated by ANSI.
2. The settings on the controller will vary slightly as the voltage supplied to the unit varies due to building and electrical supply loads increase/decrease. To allow for variations, the manufacturer recommends adding 1 second to ANSI's minimum opening or closing times. Use a stopwatch for assistance.

Electrical Power

There is a 7/8" diameter hole for electrical conduit at each end or top of the header. Remove the decorative plug from the header closest to the power source and run the power wires into the header. It is also acceptable to drill a sufficient sized hole in the back of the header and bring power in from the attaching wall or frame. Ensure that all national electrical and local building codes are followed. It is essential that the ground wire is attached to the green ground screw found on the end of the header, opposite the pivot. The ground (green) wire from the control board must also be secured under this ground screw.

It is recommended that the power be run through a 120 VAC 5 amp (or higher) rated switch or circuit breaker so that power can be easily removed for maintenance. In any case, the power must be off for these connections. Connect the hot and neutral wires to the black and white wires from the control board.

Wiring Connectors

There are four connectors located on the control board labeled J1, J2, J4, and J5 (Figure 1). There is a re-settable fuse 1 (F1) and a replaceable use 2 (F2). A wiring diagram is provided at the end of this section.

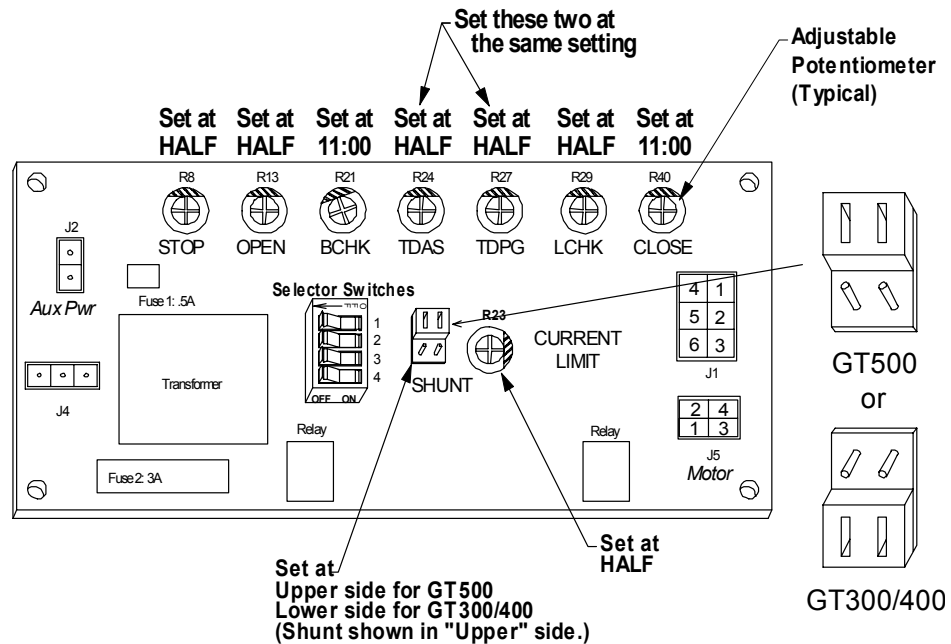

Figure 1 – Magnum Control Board.

Pin Assignments

J2 is the 24 VAC output to the actuating device. It is a two-pin connector.

1. Do not exceed 0.5 - amp current draw.
2. This circuitry was designed to work with any sensor that operates on 24 VAC. This circuitry is limited to 0.500-amp current draw and must not be exceeded. If a sensor requires a different operating voltage, a separate voltage module must be used to supply power to the sensor.

J1 is the signal input. It is a six-pin connector with a mating connector installed.

1. Pin 1 has a lock out circuit so that the signal only works when the door is in the closed or fully open position. The logic is turned off and on through back check and door closed switches. Completing the circuit from the common (pin 6) will prevent the door from opening or closing from a fully closed or fully open position. It is generally used for swing side presence detectors where the detector needs to be deactivated as the door sweeps across the detection zone. The wire to this pin is white.
2. Pin 2 should be connected to the door closed switch to determine when the door is closed and out of the detection area of the presence sensor. The wire to this pin is orange.
3. Pin 3 should be connected to the back check switch. The wire to this pin is blue.
4. Pin 4 receives the activate signal from the actuating device when someone approaches the door. The wire to this pin is black.
5. Pin 5 is used with floor mats, and other safety systems. Completing the circuit from the common (pin 6) will stop the door during opening or closing as well as prevent it from moving if it is fully open or closed. This safety circuit is always active unlike the safety circuit described for pin 1. The wire to this pin is purple.
6. Pin 6 is common, so connecting this red wire to any of the other five will cause that feature to be activated. For example, connecting the red and blue will result in back check.

J5 is the motor feed. It is a four-pin connector with a connector installed to the motor inputs. Motor Harness with resistor & diode is necessary.

1. Pin 1 is motor negative. The wire to this pin is red.
2. Pin 2 is motor positive. The wire to this pin is black.
3. Matching the color wires into the motor makes the unit work for right-hand doors. Mismatching the wires makes the unit work for left-hand doors.
4. There are no wires to the Pin 3 and 4.

NOTE: If the operator is the wrong hand, it **CANNOT** be corrected by reversing the wiring leads into the motor.

Fuses

Fuse 1 (F1) is a 0.5 amp, fuse that protects auxiliary equipment that may be connected to J2. It also protects the auxiliary power circuit of the magnum board.

Fuse2 (F2) is a 3 amp, 250 volt fuse that protects the circuit board from voltage spikes and incorrect voltage being applied to the board.

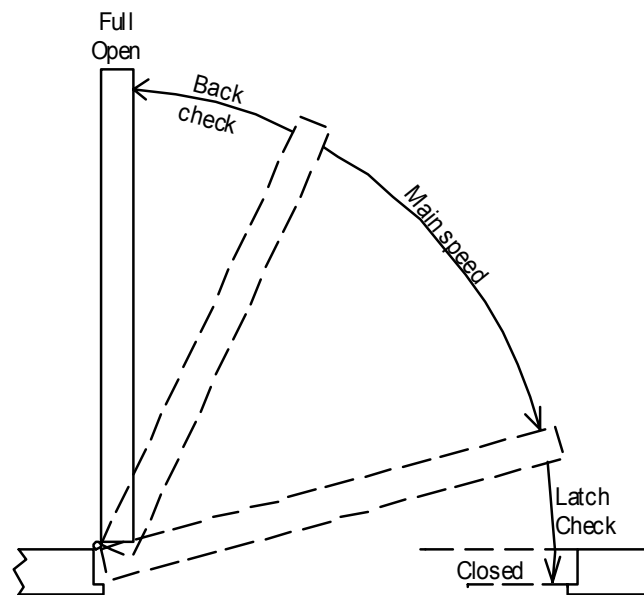

Figure 2 – Stages of Travel.

Functions

Back Check – This takes place from about the last 10° of sweep to the full open position. This angle would be changed depending upon the arm preload. Refer to Figure 3 and set the preload properly.

Closing Speed – How fast the door moves from fully open to the final 10° before fully closed.

Current Limit (or Door Block) – This sensitivity adjustments stops the activation if the door encounters an object in the path of the moving door while opening.

Latch Check–This takes place from about the last 10° of sweep to the full closed position. This angle would be changed depending upon the arm preload. Refer to Figure 3 and set the preload properly.

Opening Speed – How fast the door opens from fully closed to approximately 80° open.

Push-N-Go – Activation of the GT 300/400 by manually pushing the door. The Magnum Control board senses the power generated by rotation of the motor and energizes the activation circuit.

Time Delay Activation Signal – When the door is activated via a push plate, a mat, a sensor, etc., this option determines how long the door will stay open. It is adjustable up to 60 seconds.

Stop Adjustment – When an object is detected in the path of a moving door while opening and the door is not in back check, this feature determines whether the door stops, slowly opens, or slowly closes.

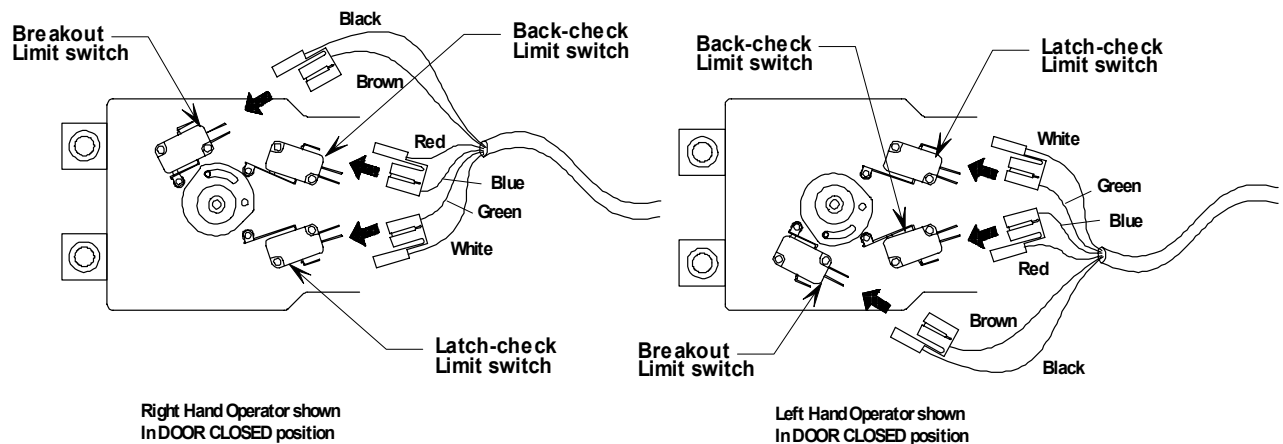

Figure 3 Limit switch configuration

Adjustments

There are three types of adjustments on the Magnum Control Board, shunt, potentiometers and selector (dip) switches. See Figure 1 for the location of these adjustments.

Shunt - The 2x2 shunt provides a connection over 4 pins of a 6 pin terminal. The exposed bars in the shunt, that can be seen from the surface must be vertically oriented for the correct pins to be jumped. If the shunt is installed in a horizontal position, the door will not function properly. (See Figure 1)

Upper side is for GT500 (Low Energy Operator).

Lower side is for GT300/400 (Standard Operator).

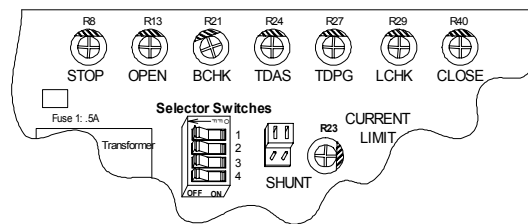

Potentiometers – There are eight potentiometers located on the control board. Use a small #0 Cross point or Phillips screw-driver to adjust each potentiometer. Don't touch other parts of the board with the screwdriver. This could damage the electrical circuitry. Adjust potentiometers clockwise to increase the parameters (speeds, stops, delays, etc.), counterclockwise to decrease the parameters. Wait at least 5 seconds before testing the change.

Recommended start settings correspond with positions on a clock with 12 o'clock at the top. The settings are a starting point. They are standard field approximations that might need to be adjusted for a specific situation.

Selector (Dip) Switches – There is one bank of four switches located on the control board. The screwdriver can be used to toggle the switches on and off. Do not use a pencil. Note that the edge of the switch bank closest to the transformer is the "Off" position.

Customized Settings

Magnum Board

Potentiometers

STOP! Changes should only be made by trained, qualified technicians.

Each control board has 8 potentiometers:

1. Stop Adjustment (STOPS)
2. Opening Speed Adjustment (OPEN)
3. Back Check Adjustment (BCHK)
4. Time Delay Activating Signal (TDAS)
5. Time Delay Push-N-Go (TDPG)
6. Latch Check Adjustment (LCHK)
7. Closing Speed Adjustment (CLOSE)
8. Current Limit Adjustment (CURRENT LIMIT)

Stop Adjustment (STOP):

When an object is sensed in the path of a moving door by a safety mat or a swing side ACUGARD sensor connected to the control board through J8 and the door is not in back check, this feature determines whether the door stops, slowly opens, or slowly closes. The recommended start setting is 12 o'clock.

Clockwise rotation of the potentiometer increases the stop power. If the stop power is increased and an object is detected in the path of the opening door, the door will continue to open, but at a slower speed. If the stop power is decreased and an object is detected in the path of the opening door, the door will stop, reverse direction, and close slowly. Rotation of the potentiometer towards the midpoint of the setting reduces the speed at which the door moves.

NOTE: This adjustment is pertinent to signals from the continuous safety connector and is not related to current limit. Also, heavier doors will require more STOP power.

Opening Speed Adjustment (OPEN):

This sets the door opening speed. The recommended starting position is 12 o'clock. Clockwise rotation increases opening speed.

GT-300/400 Application: 1.5 ~ 16 sec / 80 deg.

GT-500 Application : 3.0 ~ 16 sec / 80 deg.

Back Check Adjustment (BCHK)

This sets back check speed. Back check takes place from about the last 10° of sweep to the full-open position. The recommended starting position is 11 o'clock. Clockwise rotation increases back check speed. If back check is set too high the door will slam open. The current limit will trip. If back check is set too low the motor will not be able to move the door. The door will slowly close.

GT-300/400 Application : 0.4 ~ 10 sec / 10 deg.

GT-500 Application : 1.8 ~ 25 sec / 10 deg.

Time Delay Activating Signal (TDAS):

When the door is activated, this option determines how long the door will stay open after the activation (or input signal) is released. It is adjustable up to 60 seconds. The recommended starting position is 12 o'clock. Clockwise rotation increases time delay.

GT300/400/500 Application : 1 ~ 60 sec.

Time Delay Push-N-Go (TDPG):

When the push-n-go feature is used, this sets the time delay, which determines how long the door stays open. It is adjustable up to 60 seconds. The recommended starting position is 12 o'clock. Clockwise rotation increases time delay.

GT300/400/500 Application : 1 ~ 60 sec.

NOTE: Push-N-Go time delay, when active, should be set for a shorter length of time than the Time Delay Activating Signal.

If TDPG is not used, the time delay adjustment must be set at the same setting as time delay activating signal (TDAS). Do not set TDPG at minimum (full counter clockwise).

Latch Check Adjustment (LCHK):

This sets latch check speed. Latch check takes place from about the last 10° of sweep to the full-close position. The recommended starting position is 11 o'clock. Clockwise rotation increases latch check speed. If latch check is set too high the door will slam closed.

GT-300/400/500 Application : 1.5 ~ 5.0 sec / 10 deg.

Closing Speed Adjustment (CLOSE):

This sets the door closing speed. The recommended starting position is 12 o'clock. Clockwise rotation increases closing speed.

GT-300/400/500 Application : 3.0 ~ 12 sec / 80 deg.

Current Limit Adjustment (Current Limit):

This should be set only when the door operation is satisfactory.

In the case of GT-500, to satisfy ANSI Low Energy standard, it will be required to set this pot carefully. Although recommended setting is around 1:00 o'clock, it will be necessary to adjust setting depending upon door weight and speed.

This stops activation and cuts power to the motor if the current exceeds the setting. It is used to set how much force the opening door will push on an encountered object before it recycles. When the recycle is triggered, the door will stop and coast to a close. This adjustment is affected by opening speed. Set opening speed first. The recommended starting position for current limit might not be appropriate in windy conditions. For example, strong wind gusts against an exterior door may inadvertently cause it to recycle. Clockwise rotation makes the door less sensitive to objects in its path.

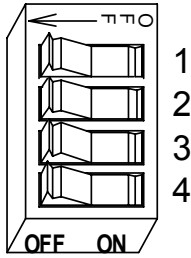

(Switches shown in "ON" position.)

Dip Switches

Switch 1 –Not used

Switch 2 – Not used

Switch 3

1. When the switch is ON, push-n-go is not active.
2. When the switch is OFF, push-n-go is activated.

Switch4

1. When the switch is ON, the door will open, time out and close.
2. When the switch is OFF, the door is in the sequential mode. One activation opens the door, a second activation is needed for the door to close.

Control Switches

An ON-OFF-HOLD OPEN switch assembly has been provided. It can be mounted inside the header or where it is easily accessible to the customer. Drill a 7/8" diameter hole in the center of the location to install the switch. Use the switch as a template to drill (2) 11/64" diameter mounting holes. Use the two screws provided to mount the switch.

Signage

After the door has been adjusted properly and tested, decals should be applied to the door such that they are visible from either side of the door. Depending on the type of the door activation, certain decals must be displayed.

Wiring to Operator

The following harnesses are necessary.

- a. Power Harness, Magnum Board
Part # 21-9933 (for single door)
14-5883 (for Simultaneous Pair door)
- b. Main Harness Assy, Magnum Board
Part # 22-10065 (for single door)
22-10270 (for Simultaneous Pair door)
- c. 300/400/500 Harness for Magnum Board
Part # 21-9934

Wiring for Rocker switch

Rocker Switch (part # 11-9935) is available. Connect the black wire to activation input, the red wire to 24VAC common and the green wire to activation signal of sensing device.

Wiring for Break – out

When the unit has a Break-out feature, some modification would be required. Please, refer to the following procedure.

- a. Panic Latch kit:
Flip the direction of the panic latch so that the “← EXIT” arrow points to Interior side of the building. (This makes the switch close instead of opening when the door is broken out. The contacts of the switch would be changed to Normally Open from Normally Close.)

Bottom View of Panic Latch

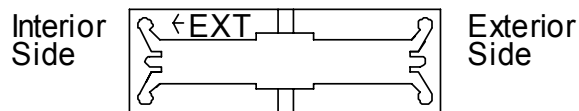

- b. Cut the connectors to the “Panic Latch” and/or the “300/400/500 harness” as shown below.

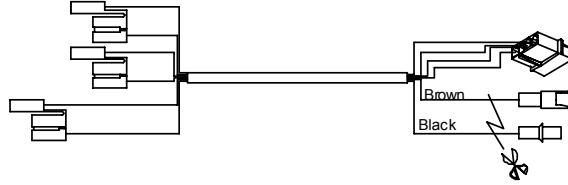

- c. Connect these wires to “Continuous Safety” input of Terminal Block.(Between Terminal Block #3 violet and #5 red)

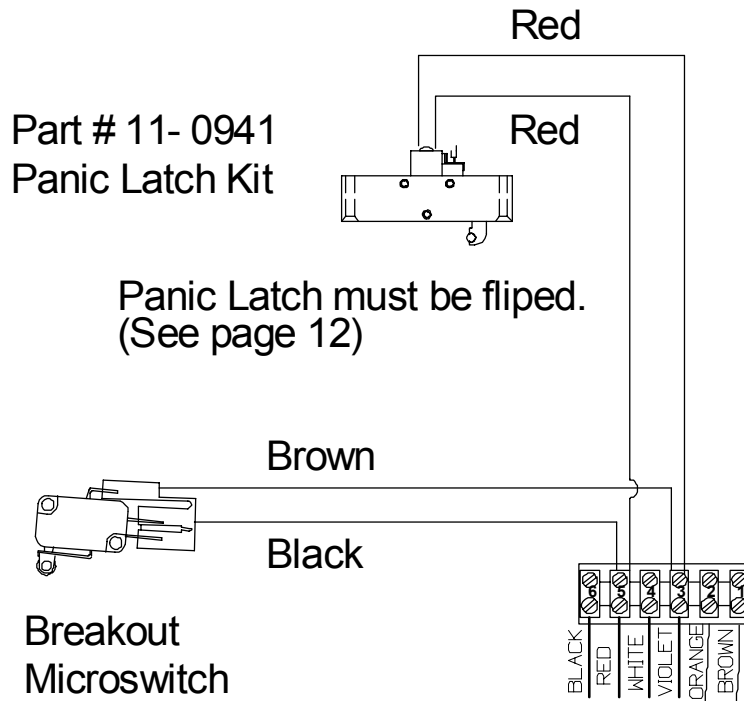

TERMINAL BLOCK		
#1	BROWN	24VAC NEUTRAL
#2	ORANGE	24VAC HOT
#3	VIOLET	CONTINUOUS SAFETY
#4	WHITE	SAFETY WITH LOCKOUT
#5	RED	24VAC COMMON
#6	BLACK	ACTIVATION

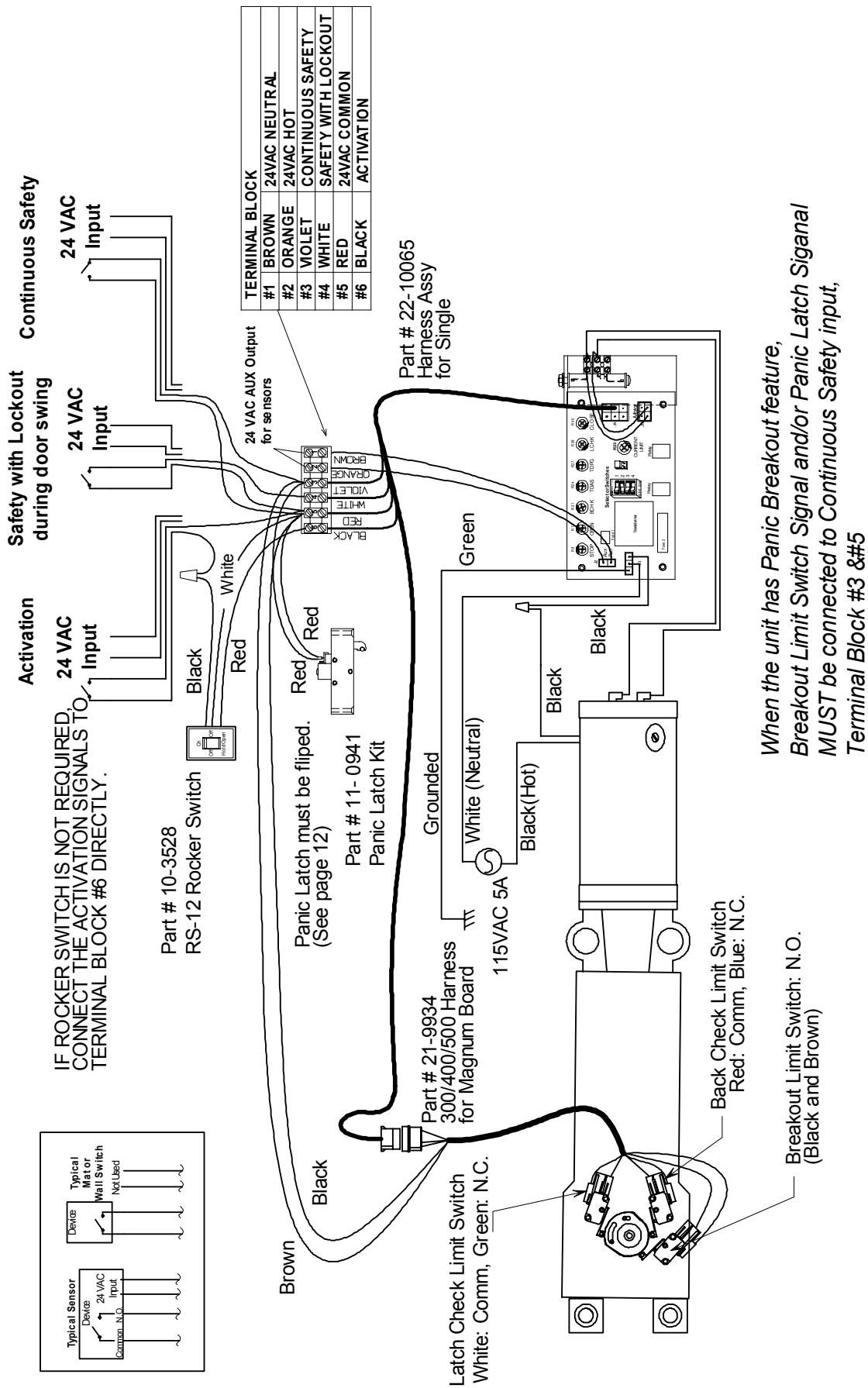

General Wiring - Single Diagram

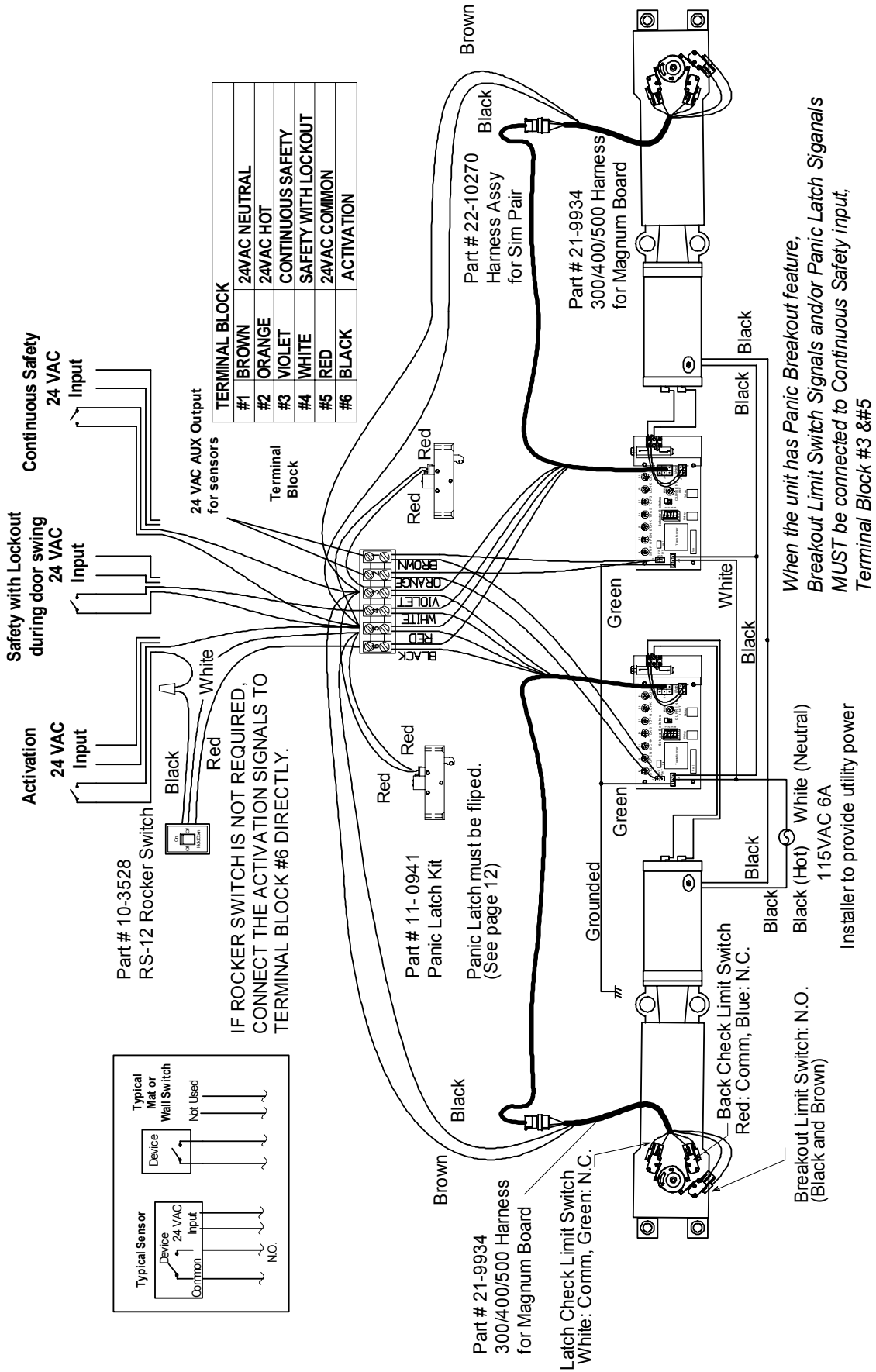

General Wiring – Simultaneous Pair