

NABCO ENTRANCES INC.

S82 W18717 Gemini Dr., PO Box 906

Muskego, Wisconsin 53150

Tel: 1-877-622-2694

Fax: 1-888-679-3319

<http://www.nabcoentrances.com>

A founding member of:

AAADM

American Association of Automatic Door Manufacturers

AUTOMATIC SWINGING DOOR

OWNER'S MANUAL

Distributed by:



Section	Contents	Page
Caution		2
To Our Customers		3
Service Availability		3
Compliance with Safety Standards		3
What You Should Know		4
Daily Safety Check		5
Operation		8
Limited Warranty		8



CAUTION

An Improperly Adjusted Door can cause injury and/or equipment damage.

Inspect door operation daily using safety checklist in Owner's Manual and at door.

Have door adjusted as described in Owner's Manual.

Safety devices should be in place and operational.

Have door inspected at least annually by an *AAADM* certified inspector.

In the following manual, the word:

Caution means that injury or property damage can result from failure to follow instructions.

Note is used to indicate important steps to be followed or important differences in equipment.

To Our Customers

The purpose of this manual is to familiarize you with your automatic door system. It is essential that you "know your system" and that you recognize the importance of maintaining your door system in compliance with the industry standards for safety.

It is your responsibility, as owner or caretaker of the equipment, to inspect the operation of your door system on a daily basis to ensure that it is safe for use by your invitees, customers, or employees.

This manual will provide you with a description of the operation and maintenance requirements of your door. It also provides the instructions for the *Daily Safety Check*.

Should the door fail to operate as prescribed in the *Daily Safety Check*, or at any other time for any other reason, **do not attempt to repair or adjust the door**. Call an AAADM Certified service technician. These technicians are trained to service your door in accordance with applicable industry safety standards.

Service Availability

Automatic door products are distributed through a nationwide network of authorized automatic door suppliers for sales, installation, and service.

Should you need service on your door system, consult the respective door manufacturer or its authorized representative.

Compliance with Safety Standards

Your door system was designed to the latest operating and safety standards. In order to ensure the continued safe operation of your door, it is important that:

- Your door system be maintained in compliance with the standards of the industry.
- Proper signage and labels be applied and maintained on your doors. If signage is removed or cannot be read, request replacements when calling for service.
- All doors should be checked by an AAADM certified inspector at least annually.

AAADM, the American Association of Automatic Door Manufacturers, has established a program to certify automatic door inspectors. Through this program, the inspectors are trained to check your door systems for compliance with the American National Standards Institute standard ANSI/BHMA A156.10.

DOOR OPERATION – SWITCHES

Your door may be equipped with one of the following types of switches.

ON / OFF / HOLD OPEN Activation Switch

A. ON

1. When the switch is in **ON** position, all signals are accepted and the door is ready for operation.

OFF

2. When the switch is in **OFF** position, the activation signal is shut off from sensors to the control box. The OFF position does not shut off the power.

HOLD OPEN

3. When the switch is in **HOLD OPEN** position, doors are held open as long as the switch remains in this position. The doors should be held open in this manner. Do not prop open the doors with any object.

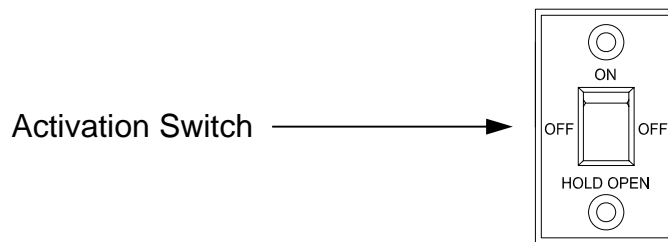

OFF / ON / HOLD OPEN Activation Switch

B. OFF

1. When the switch is in **OFF** position, the activation signal is shut off from sensors to the control box. The OFF position does not shut off the power.

ON

2. When the switch is in **ON** position, all signals are accepted and the door is ready for operation.

HOLD OPEN

3. When the switch is in **HOLD OPEN** position, doors are held open as long as the switch remains in this position. The doors should be held open in this manner. Do not prop open the doors with any object.

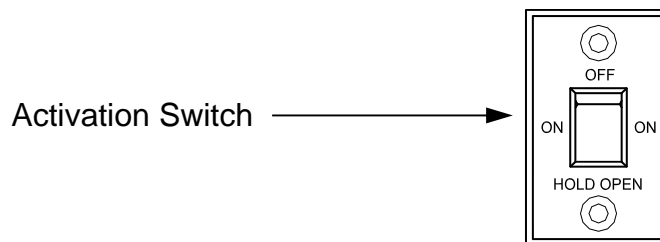

Note: To shut off the power, turn off the circuit breaker in the building's electrical box.

ACUSENSOR OPERATION

- A. Acusensors are latest in pedestrian traffic sensing technology. Acusensors cause the door to open by sending door opening signals to the sliding door control.
- B. In simple terms, when power is supplied to the Acusensor, it “sees” its environment including the floor and memorizes its appearance. When this appearance changes (when someone walks into the volume) the Acusensor sends a “door open” signal.
- C. Appearance changes include:
 - 1. A person, cart or forklift.
 - 2. When common objects are left or moved into the sensing area, such as:
 - * Carpets or mats
 - * Boxes
 - * Displays or merchandise
 - * large pieces of paper
- D. If the background changes and remains constant for thirty seconds, the sensor will memorize it. The doors will remain open or closed until memorization takes place.

What You Should Know

Be sure that an automatic door supplier has provided the following for each door:

1. Instruction on how to conduct the *Daily Safety Check* ^{*} (by walk-through example).
2. Location of function switches and instruction in their use.
3. Circuit breaker or main power disconnect location for each door system.
4. Number to call for service or questions about your system if you are uncertain of any condition or situation.
5. AAADM inspection form or a work order signed by an AAADM certified inspector.
6. A completed Annual Compliance Inspection label, located at the bottom of the Safety Information label affixed to the door.
7. Warranty information for each door.

Note: If there are any problems, or if you are unsure about the safe performance of the door, **discontinue door operation immediately** and secure the door in a safe manner. Call your authorized automatic door professional for repairs.

^{*}**Note:** AAADM Daily Safety Check videos are available. Contact an automatic door supplier or AAADM.

Automatic swinging doors are installed in a variety of combinations.

- Doors Swing In - Swing Out in Emergencies
- Doors Swing Out
- Single, Pairs, or Double Egress
- One-Way Traffic or Two-Way Traffic
- Activated by Floor Mat, Sensors, or Push Switches

They always require the following safety items:

- A Safety Zone to cover the area the door travels.
- Guide Rails on the swing side of the door (unless a wall is in the same position).

Daily Safety Check (All figures and diagrams are for purposes of illustration only)

Perform the following safety checks *daily* on each automatic swinging door to ensure your customers' safety and your own protection. Perform these tests while traffic is restricted from all detection and sensing zones.

Sensor Activation / Presence Detection Safety

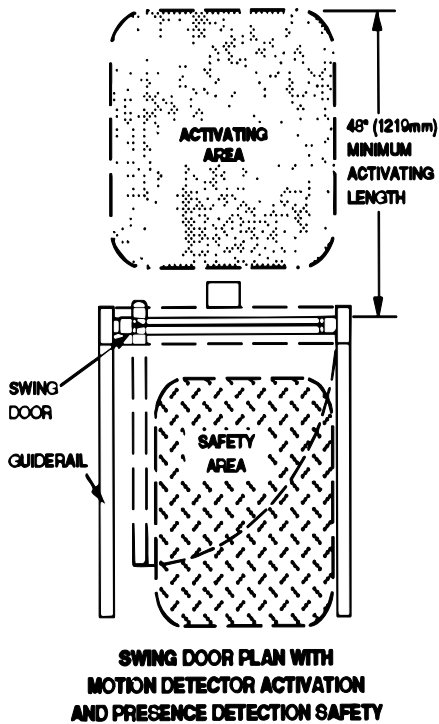

Figure 1

1. Check electronic sensor by walking toward the door opening at a moderate speed. The door should start opening when you are about four feet from the door, should open smoothly and stop at fully open without impact. Move slowly through the door opening (6 inches per second), stop in the swing path and pause for 10 seconds. The door should remain open. If two way traffic, repeat from the other side of the door.
2. Step out of the sensor zone. After a brief time delay (at least 1 1/2 seconds) the door should close smoothly and without impact.
3. For one way traffic doors, approach the safety side of the door, then have someone else approach the activating side of the door.

- If the door is equipped with an overhead mounted presence sensor, as long as you are in the safety area of the door it should not open. (See Figure 1)
- If the door is equipped with a door mounted presence sensor, the door may start to open but should reverse, stop, or slow down. (See Figure 2).

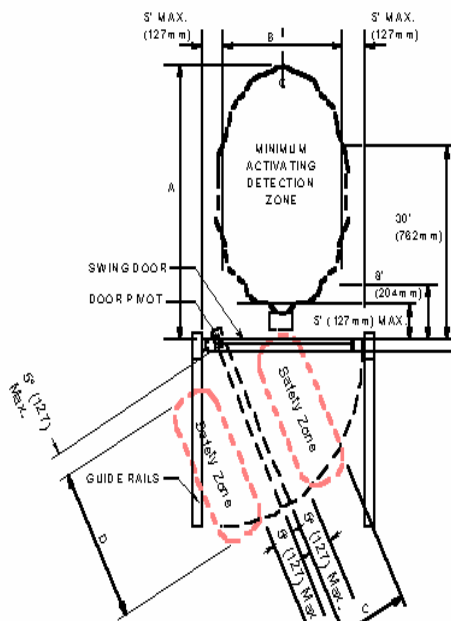

Figure 2

4. Crouch motionless in the door opening for at least 4 seconds.

- If the door is equipped with an overhead mounted presence sensor, the door should not close.
- If the door is equipped with a door mounted presence sensor, the door should reverse, stop, or slow down.

Caution: If safety sensor is not working, door may swing toward you without stopping.

Floor Mat Activation/Floor Mat Safety

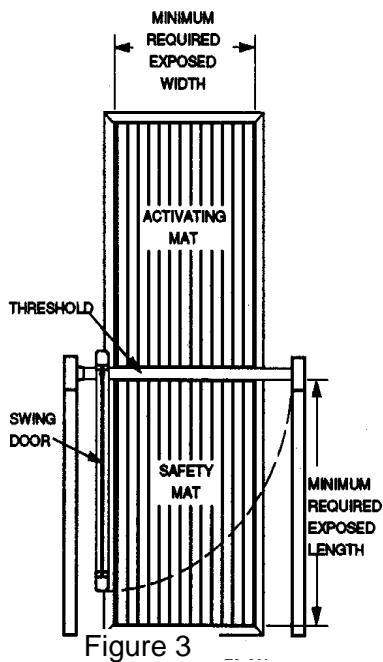

Figure 3

1. Step on the "opening" (activating) mat.
2. It is necessary to have a safety mat covering the entire area the door swings over. Step through the doorway onto the safety mat and remain motionless for 4 seconds. The door should remain open. Repeat at several locations on the mat. (See Figure 3 or 4)
3. Step off the safety mat. After a brief time delay (at least 1 1/2 seconds) the door should close smoothly and without impact.
4. With the door closed, step on the safety mat on the swing side. Have someone step on the activating mat. Door should remain closed as long as someone remains on the safety mat.

Caution: If safety mat is not working, door may swing toward you without stopping.

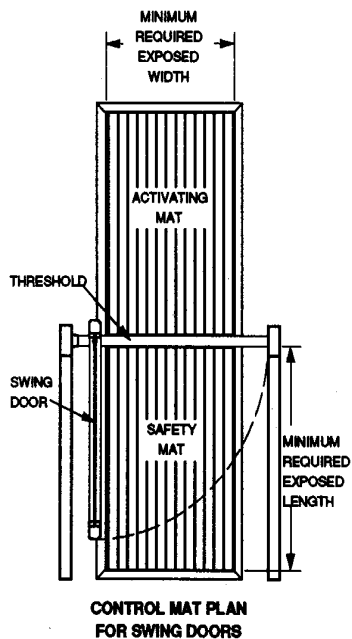

Figure 4

5. Check the mat molding and threshold. It should be complete and secured with all required screws.

Double Egress-Using Knowing Act

1. Double Egress doors are commonly activated by a knowing act switch. Momentarily operate knowing act switch. Doors should open smoothly and stop at fully open without impact. Doors should remain fully open for a minimum of 5 seconds before closing.
2. As the door closes, approach the door from the non-swing side, and the door should reopen. Continue across the threshold and stand motionless for 10 seconds. Door should not contact you.
3. Continue through the door and the door should start closing after a minimum of five seconds. Door should close smoothly and without impact.
4. Approach the safety side of the door. Have someone else activate the knowing act switch. If the door is equipped with an overhead mounted presence sensor, as long as you are in the safety area of the door, it should not open. (See Figure 5)
5. If the door is equipped with a door mounted presence sensor, the door may start to open but should reverse, stop, or slow down. (See Figure 6)
6. Repeat for the other door panel.

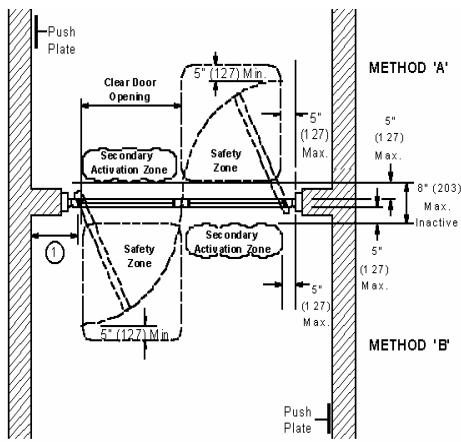

Figure 5

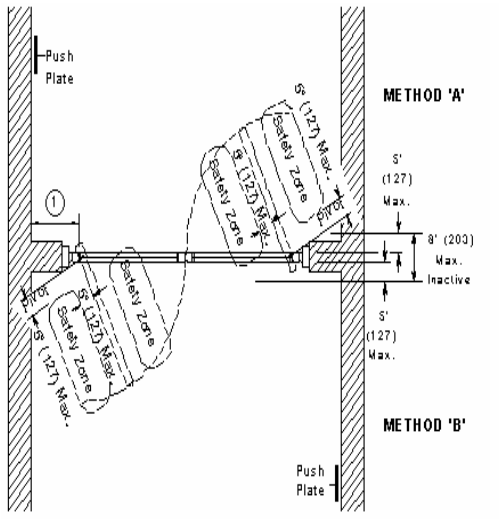

Figure 6



Figure 7



Figure 8



Figure 9

General Safety

Pay attention to the following general safety items and conduct checks periodically where noted.

1. **Force.** Force to prevent the door from closing should not exceed 30 pounds. This can be measured with a force gauge.
2. **Breakout Stop.** Center pivoted in-swinging doors may be supplied with an emergency breakout stop or switch that will allow the door to open in the direction of emergency egress. Call your supplier for details.

When the door is pushed into the breakout mode, check that door will not activate.

3. **Signage.** The door should have decals properly displayed as follows at a height 58 inches, ± 5 inches from the floor to the centerline of the sign (unless otherwise noted). The decal shall be a minimum of 6 inches in diameter (unless otherwise noted):
 - A. If one way traffic, an arrow (See Figure 7) shall be visible from the approach side of a swinging door, mounted on the door. The decal shall have a green circle surrounding a black arrow on a white background. The words "Automatic Door" with letters $\frac{1}{2}$ inch high shall be visible from the approach side.
 - B. If one-way traffic, an international "DO NOT ENTER" decal (See Figure 8) shall be visible from the side that would swing toward pedestrians attempting to travel in the wrong direction. The decal shall have a red circle with the wording, "Do Not Enter", in white letters in the red circle. The words "Automatic Door" with letters $\frac{1}{2}$ inch high shall be visible from the side that would swing toward pedestrians attempting to travel in the wrong direction.
 - C. Swinging doors serving two-way traffic shall be marked with a decal, visible from both sides of the door, with the words "Automatic CAUTION Door". (See Figure 9) The letters in the words "Automatic Door" must be at least $\frac{1}{2}$ inch high. The sign shall be made with black lettering on yellow background.
 - D. One way traffic doors shall be marked on the non swing side with a decal with the words "Automatic Door". The letters in "Automatic Door" must be at least $\frac{1}{2}$ inch high.
 - E. Double egress doors shall be marked with a decal, visible from the swing side of the door, with the words "Automatic CAUTION Door". On the non-swing side, the words

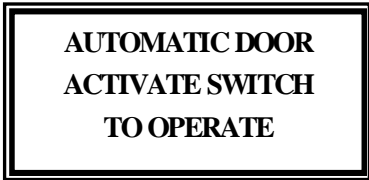

Figure 10

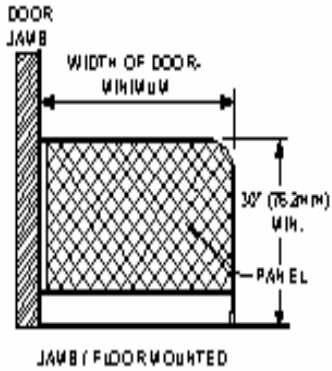

Figure 11

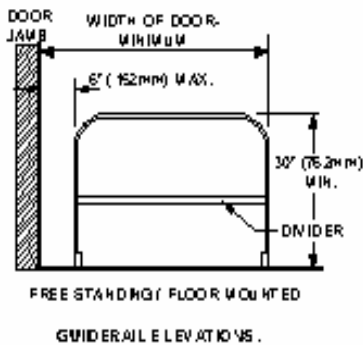

Figure 12

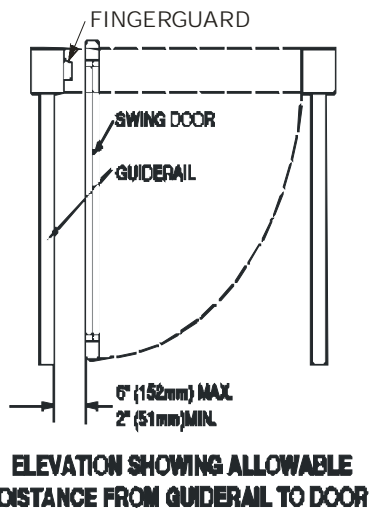

Figure 13

“Automatic Door” with letters ½ inch high shall be visible.

- F. An AAADM safety information label should be affixed on the door or frame in a protected, visible location. If you need additional decals or labels for automatic doors, call your automatic door supplier.

- 4. Activating Switch. (Knowing Act) Doors equipped with a manual activating switch shall hold fully open for a minimum of 5 seconds before closing.

Doors equipped with a manual activating switch shall have a decal as follows: “Automatic Door. Activate Switch to Operate.” The decal should be visible from both sides of the door or the side with the knowing act switch if there is only one. (See Figure 10).

- 5. Guide Rails. Check that guide rails or other barriers or separators are present (two per swing door side) and firmly anchored. Rail length should be the width of the open door or greater. (See Figures 11, 12, 13).

- 6. Lock Stile. With door open, grasp lock stile of door and attempt to move vertically and horizontally. There should be no looseness in the door pivots or in connections between door and operator.

- 7. Housekeeping. Check the door area for tripping or slipping hazards.

Check all door panels for damage. Make sure that all hardware and overhead covers are properly secured. There should be no bulletin boards, literature racks, merchandise displays, or other attractions in the door area that would interfere with use of the door or invite people to stop or stand in the door area.

- 8. Traffic Patterns. Observe traffic patterns. Plan routing so people enter and exit in a straight approach, directly toward the center of the door opening.

- 9. Finger Guard. If installed, inspect finger guard to see that it is secure and in good repair. (See Figure 13)

IF YOU HAVE A PROBLEM, TURN OFF THE DOOR OPERATING EQUIPMENT AND CALL AN AUTOMATIC DOOR SUPPLIER FOR PROMPT REPAIRS TO BE MADE.

Operation

Please refer to NABCO/Gyro-Tech Installation Manual for details of operation.

Limited Warranty

NABCO Entrances Inc., for its Gyro-Tech product line, provides to its purchasing distributor a limited warranty on the equipment supplied by NABCO Entrances Inc. The warranty is:

NABCO Entrances Inc. will exchange or repair, F.O.B. the NABCO Entrances Inc. plant any unit component found defective in workmanship and/or material, subject to NABCO inspection, for a period of one (1) year from date of installation. Warranty does not include field service labor. The installing contactor/distributor shall be responsible for installation and field service.

This warranty does not cover loss or damages resulting from causes beyond the manufacturer's control, or misuse, neglect, accident, wind storm, acts of terrorism or acts of God. Warranty is for normal use and service. The warranty will not apply for equipment which has been repaired or altered so as to adversely affect conditions of operation. Warranty will not obligate NABCO for damages resulting from such alterations, misuse, neglect, terrorism or acts of God.